

# DESIGN NOTES

## Isolated DC/DC Conversion with the LT1425 – Design Note 158

Kurk Mathews

The LT<sup>®</sup>1425 is designed for applications requiring well regulated, isolated voltages, such as isolation amplifiers, remote sensors and telecommunication interfaces. A unique feedback amplifier eliminates the need to cross the isolation barrier twice, resulting in a simpler, lower parts count supply. The LT1425, available in 16-pin SO, is a 275kHz current mode controller with an integral 1.5A switch, designed primarily to provide well regulated, isolated voltages from 3V to 20V sources.

Figure 1 shows a typical flyback LAN supply, including an alternate transformer for a complete PCMCIA type II height solution. Load regulation is  $\pm 1\%$  for output currents of 0mA to 250mA. Feedback is accomplished by averaging the flyback voltage on the primary side of T1. The internal switch is located between the V<sub>SW</sub> and P<sub>GND</sub> pins. The R<sub>FB</sub> pin is internally biased to V<sub>IN</sub>. During the switch off-time, a feedback current proportional to V<sub>OUT</sub>/n (n is the transformer's turn ratio) is developed into the R<sub>FB</sub> pin (via R4). Flyback voltage on T1 is not present during the switch on-time or when the secondary current decays to zero

(discontinuous flyback mode). Collapse-detect and blanking circuitry ensure that the feedback amplifier ignores information during these times.

Resistor R3 provides additional load compensation, necessary to compensate for winding resistance and output diode voltage drop. It generates a current proportional to the average switch current (and therefore, to load current). This current subtracts from the feedback signal, compensating for the parasitic voltage drops that tend to lower the output voltage with increasing load.

The result of this feedback method is excellent load regulation and fast dynamic response not found in similar isolated flyback schemes. Referring again to Figure 1, the  $-9V$  output changes only 300mV during a 50mA to 250mA load transient.

Figure 2 shows a  $\pm 5V$  supply with 1.5kV of isolation. The sum of line/load/cross regulation is better than  $\pm 3\%$ . Full load efficiency is between 72% (V<sub>IN</sub> = 5V) and 80%

LT, LTC and LT are registered trademarks of Linear Technology Corporation.

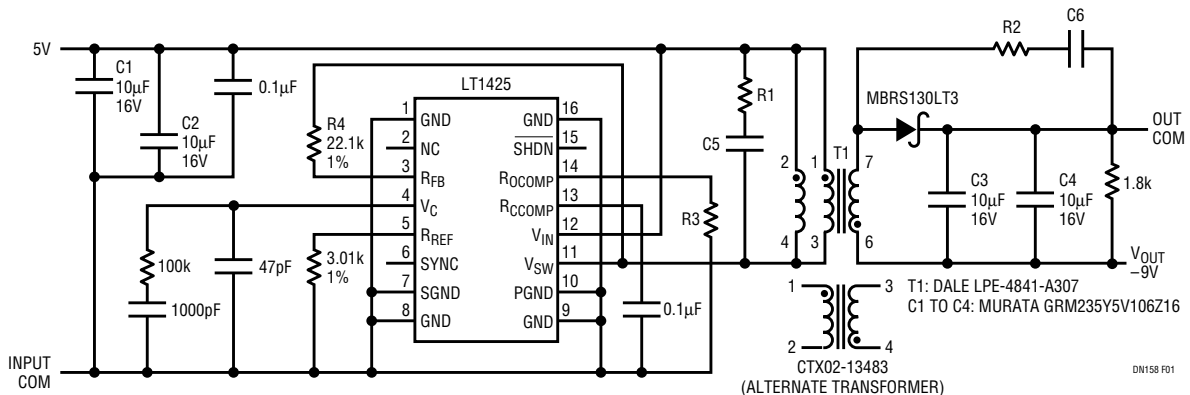

### Transformer T1

	LPRI	RATIO	ISOLATION	(L × W × H)	I <sub>OUT</sub>	EFFICIENCY	R1, R2	C5, C6	R3
DALE LPE-4841-A307	36μH	1:1:1	500VAC	10.7 × 11.5 × 6.3mm	250mA	76%	47Ω	330pF	13.3k
COILTRONICS CTX02-13483	27μH	1:1	500VAC	14 × 14 × 2.2mm	200mA	70%	75Ω	220pF	5.9k

Figure 1. 5V to  $-9V/250mA$  Isolated LAN Supply

( $V_{IN} = 15V$ ). The isolation voltage is ultimately limited only by bobbin selection and transformer construction.

In Figure 3, an external cascoded 200V MOSFET is used to extend the LT1425's 35V maximum switch voltage limit. The input voltage range (36V to 72V) also exceeds the LT1425's 20V maximum input voltage, so a bootstrap winding is used. D1, D2, Q2, Q3 and associated compo-

nents form the necessary start-up circuitry with hysteresis. When C1 charges to 15V, switching begins and the bootstrap winding begins to supply power before C1 has a chance to discharge to 11V. Feedback voltage is fed directly through a resistor divider to the  $R_{REF}$  pin. The load compensation circuitry is bypassed, resulting in  $\pm 5\%$  load regulation.

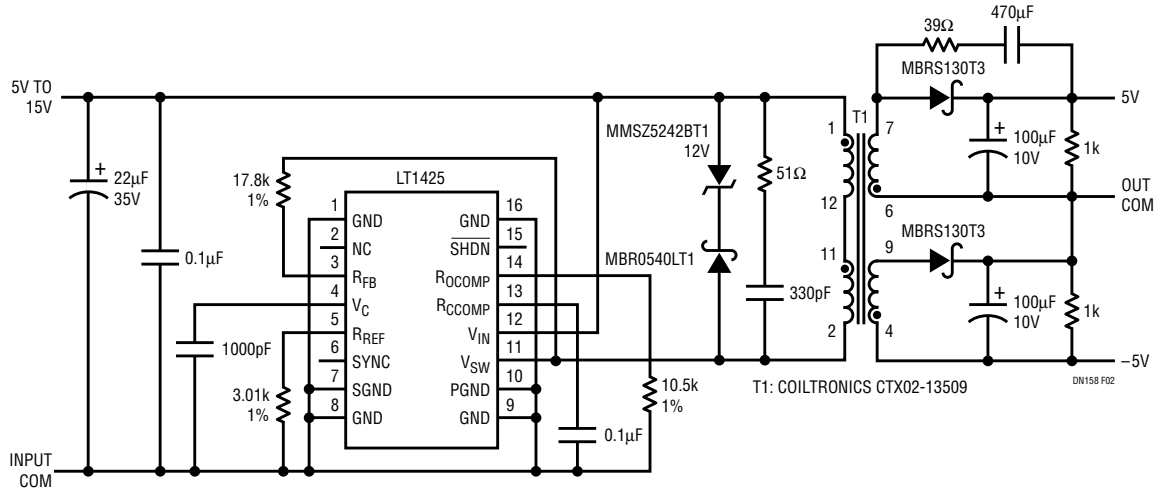

Figure 2. Fully Isolated  $\pm 5V$ ,  $\pm 220mA$  Supply

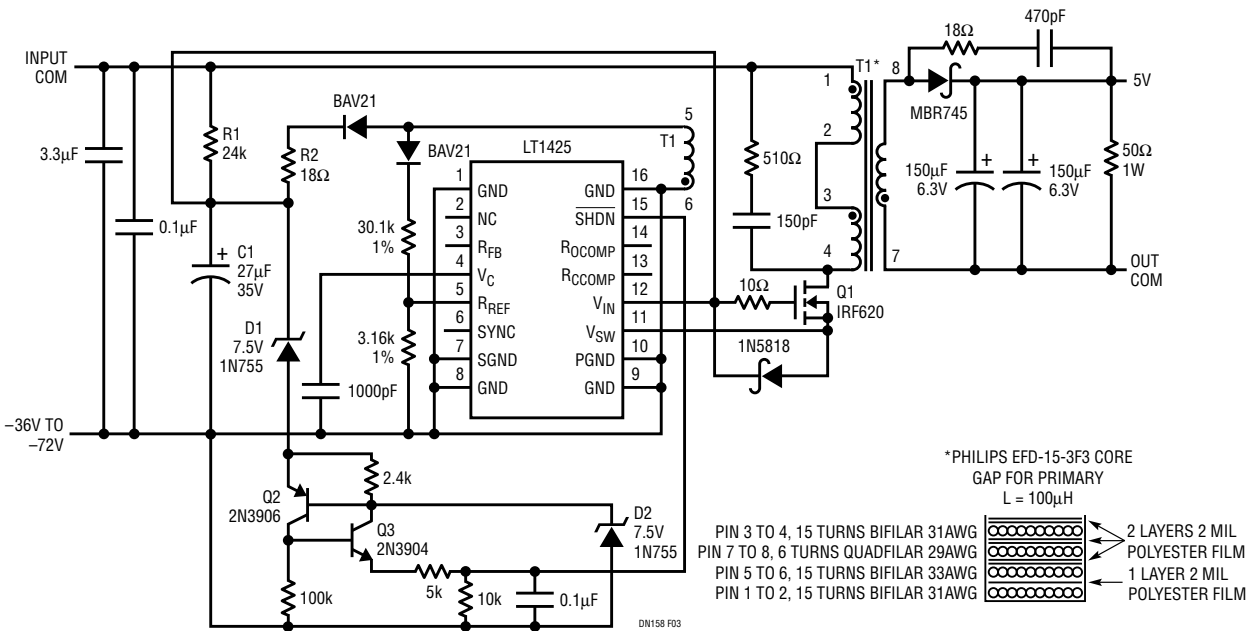

Figure 3. 5V/2A Telecommunications Supply

For literature on our Switching Regulators, call **1-800-4-LINEAR**. For applications help, call (408) 432-1900, Ext. 2360